

CARATTERISTICHE MECCANICHE - MECHANICAL SPECIFICATIONS

Dimensioni - Dimensions: vedi disegni - see drawings
Albero - Shaft: acciaio inox - stainless steel
Carico sull'albero - Shaft loading: assiale - axial: 25 N; radiale - radial 25 N
Numero giri - Shaft rotational speed: 6.000 RPM continui - continuous
Vita dei cuscinetti - Bearings life: 5 x 10⁸ giri (minimo) - rev. min.
Peso - Weight: ~1,1 kg Assiale - Axial; 1,3 Kg Radiale (senza flangia) - Radial (without flange)

CARATTERISTICHE ELETTRICHE - ELECTRICAL SPECIFICATIONS

Codici STD - STD codes: GRAY - BINARIO - BCD - ECCESSO 3 - ANALOGICO; GRAY - BINARY - BCD - EXCESS 3 - ANALOG
Frequenza in uscita - output frequency: da 0 a 20 kHz (L.S.B. senza errore); from 0 to up 20 kHz (L.S.B. without error)
Protezione - Protection: contro inversione di polarità (escluso 5Vcc); against inversion of polarity (except 5Vcc)

MATERIALI UTILIZZATI - MATERIALS

Corpo - Flange: in alluminio anticoroda anodizzato - aluminium non corroding passived
Custodia - Housing: in alluminio anticoroda anodizzato - aluminium non corroding passived

CARATTERISTICHE AMBIENTALI - ENVIRONMENTAL SPECIFICATIONS

Temperatura di lavoro - Operating temperature range: -20°C ÷ +45°C
Temperatura di stoccaggio - Storage temperature range: -40°C ÷ +85°C
Umidità relativa - Relative humidity: 98% RH senza condensazione - RH without condensing
Vibrazioni - Vibrations: 10 g (da 10 a 2.000 Hz) - (From 10 up to 2.000 Hz)
Schock - Schock: 20 g(per 11 ms) - (for 11 ms)



HAZARDOUS LOCATIONS CLASS I,
DIV. 1, GROUPS C AND D



CE 0539 II 2 G
EEEx d IIB T6
05 ATEX 140087 (*)

(*) Certificato non ancora aggiornato secondo l'ultima
revisione della normativa di riferimento.
(*) This certificate is not yet referring to the latest standard

CODICE DI ORDINAZIONE - ORDERING CODE

TIAEEX70 . **XXX** . **XXXX** . **XXXX** . **XXXXX** . **K4** . **XX** . **XXnn** . **XXXX** . **XXXX** . **Xnnn**

MONTAGGIO - ASSEMBLY

F Flangia Quadra - Square flange
S Servo - servo
FRE Flangia - Flange REO 444

Albero - Shaft

10 Ø 10 mm
11 Ø 11 mm x 28 mm

OPZIONI - OPTIONS

U Up/Down NPN
D Up/Down PNP
S Strobe standard (vedi tabella - see table; NO x SSI)
V Segnale di zero - Zero out (NO x SSI)
E Parità "Even" o parità Pari - Even parity (NO x SSI)
O Parità "Odd" o parità Dispari - Odd parity (NO x SSI)
L Latch NPN - Latch NPN

CODICE - CODE

A Uscita analogica (1024/360°-180°-90°-45°)
Analog output (1024/360°-180°-90°-45°)
B codice Binario naturale Binary code natural
B/0 codice Binario troncato centro Binary code centrally cut
B/7 codice Binario /eccesso (18) Binary code/exc (18)
B/14 codice Binario /eccesso (36) Binary code/exc (36)
B/19 codice Binario /eccesso (90) Binary code/exc (90)
B/28 codice Binario /eccesso (72) Binary code/exc (72)
B/38 codice Binario /eccesso (180) Binary code/exc (180)
B/76 codice Binario /eccesso (360) Binary code/exc (360)
B/152 codice Binario /eccesso (720) Binary code/exc (720)
B/304 codice Binario /eccesso (1440) Binary code/exc (1440)
D codice BCD (100+7200) BCD code (100+7200)
E codice Gray Exc 3 (100+2000) Excess 3 Gray code (100+2000)
G codice Gray naturale Natural Gray code
G/0 codice Gray troncato centr Centrally cutted Gray code
G/7 codice Gray /eccesso (18) Gray code/exc (18)
G/14 codice Gray /eccesso (36) Gray code/exc (36)
G/19 codice Gray /eccesso (90) Gray code/exc (90)
G/28 codice Gray /eccesso (72) Gray code/exc (72)
G/38 codice Gray /eccesso (180) Gray code/exc (180)
G/76 codice Gray /eccesso (360) Gray code/exc (360)
G/152 codice Gray /eccesso (720) Gray code/exc (720)
G/304 codice Gray /eccesso (1440) Gray code/exc (1440)

Alimentazione (Vdc) - Supply voltage

5 +5 V ± 5 % ; 11/30 +11V +30 V
18/30 +18V +30 V solo analogico - only analog

PASSI PER GIRO - STEPS

16	16 passi/giro G;B	steps/tum G;B	360	360 passi/giro G;B	steps/tum G;B
18	18 passi/giro G;B	steps/tum G;B	400	400 passi/giro G;B	steps/tum G;B
32	32 passi/giro G;B	steps/tum G;B	500	500 passi/giro G;B	steps/tum G;B
36	36 passi/giro G;B	steps/tum G;B	512	512 passi/giro G;B	steps/tum G;B
64	64 passi/giro G;B	steps/tum G;B	720	720 passi/giro G;B	steps/tum G;B
90	90 passi/giro G;B	steps/tum G;B	900	900 passi/giro G;B	steps/tum G;B
100	100 passi/giro G;B	steps/tum G;B	1000	1000 passi/giro G;B	steps/tum G;B
128	128 passi/giro G;B	steps/tum G;B	1024	1024 passi/giro G;B	steps/tum G;B
180	180 passi/giro G;B	steps/tum G;B	1440	1440 passi/giro G;B	steps/tum G;B
200	200 passi/giro G;B	steps/tum G;B	2000	2000 passi/giro G;B	steps/tum G;B
250	250 passi/giro G;B	steps/tum G;B	2048	2048 passi/giro G;B	steps/tum G;B
256	256 passi/giro G;B	steps/tum G;B			

VALORI STROBE - STROBE VALUE

S=	Strobe custom	S 201	Strobe 200 µs	S 502	Strobe 5 ms	S 104	Strobe 100 ms
S 200	Strobe 20 µs	S 501	Strobe 500 µs	S 103	Strobe 10 ms	S 204	Strobe 200 ms
S 500	Strobe 50 µs	S 102	Strobe 1 ms	S 203	Strobe 20 ms		
S 101	Strobe 100 µs	S 202	Strobe 2 ms	S 503	Strobe 50 ms		

CIRCUITI DI USCITA - OUTPUT CIRCUITS

10	NPN 40 mA Open Collector log+	31	Uscita analogica 4÷20 mA (solo 18/30V)
11	NPN 40 mA pull-up log+ (solo 11/30V - 11/30V only)		Analog output 4÷20 mA (18/30V only)
12	NPN 40 mA Open Collector log-	32	Uscita analogica 1÷5 V (solo 18/30V)
13	NPN 40 mA pull-up log- (solo 11/30V - 11/30V only)		Analog output 1÷5 V (18/30V only)
20	PNP 100 mA Open Collector log+	33	Uscita analogica 0÷10 V (solo 18/30V)
21	PNP 100 mA pull-down log+ (solo 11/30V - 11/30V only)		Analog output 0÷10 V (18/30V only)
22	NPN 100 mA Open Collector log-		
23	NPN 100 mA pull-up log- (solo 11/30V - 11/30V only)	S13D	SSI 13 bit allin destra (solo 11/30V)
30	Push Pull protetto cc (solo 11/30V)		SSI 13 bit right alignment (11/30V only)
	Push Pull cc protect (11/30V only)		

CONNESSIONI ELETTRICHE - ELECTRICAL CONNECTIONS

RAnn raccordo 1/2" GAS maschio assiale con cavo da 1 a 6 m;
on axial tap nipple 1/2" GAS with cable 1 ÷ 6 m long
RLnn raccordo 1/2" GAS maschio radiale con cavo da 1 a 6 m;
on radial tap nipple 1/2" GAS with cable 1 ÷ 6 m long
GAnn raccordo 1/2" GAS femmina assiale con cavo da 1 a 6 m;
on axial female nipple 1/2" GAS with cable 1 ÷ 6 m long
GLnn raccordo 1/2" GAS femmina radiale con cavo da 1 a 6 m;
on radial female nipple 1/2" GAS with cable 1 ÷ 6 m long
nn Lunghezza cavo - Cable length (es. PL10 = 1 m. ... PL60 = 6 m)

Grado di protezione - Protection class

K4 IP 64 (EN60529)

100	100 passi/giro E;D	steps/tum E;D
250	250 passi/giro E;D	steps/tum E;D
360	360 passi/giro E;D	steps/tum E;D
400	400 passi/giro E;D	steps/tum E;D
500	500 passi/giro E;D	steps/tum E;D
720	720 passi/giro E;D	steps/tum E;D
900	900 passi/giro E;D	steps/tum E;D
1000	1000 passi/giro E;D	steps/tum E;D
1440	1440 passi/giro E;D	steps/tum E;D
2000	2000 passi/giro E;D	steps/tum E;D

**MONTAGGIO MECCANICO
MECHANICAL ASSEMBLY**

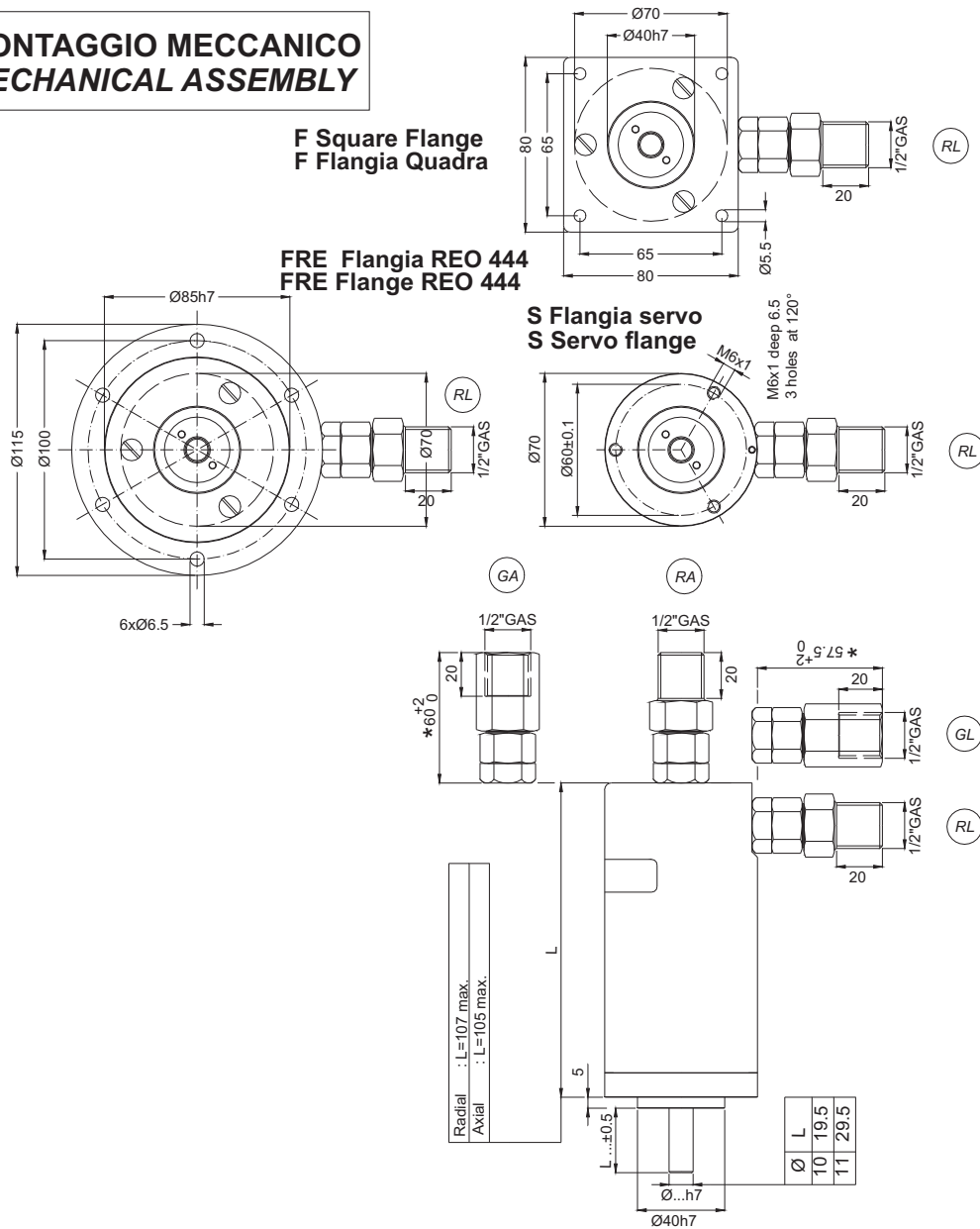

Execution according to:

**ATEX CEI EN 60079-0/60079-1
UL1203
C22.2 N°. 30-M1986**

Certification code **EEx-d IIB T6** means:

- **EEx** : means that the device has been certified according to the ATEX and UL/CSA safety rules;
- **d** : flame proof case
- **II** : Device certified for operation in potentially explosive areas except the mines in which grisou gas is present; (hazardous locations)
- **B** : Suited for the use in environments containing gases/fumes of Ethylene, Propane
- **T6** : Maximum body surface temperature 85 °C